

# Innovative UltraRack™

## Paint Stand • Assembly Instructions

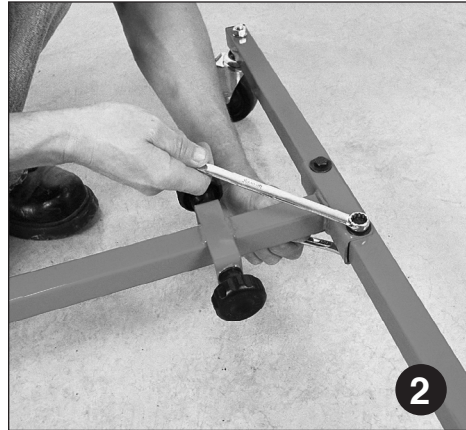

**1**  
**Install Total Lock Caster Wheels.**  
Secure to Support Tubes P/N 220-001.



**2**  
**Attach Support Tubes** to Frame Base tube (P/N 220-002); tighten firmly.



**3**  
**Attach Frame Post** (P/N 220-003) to Frame Base Tube; tighten firmly. Insert T-handle.



**4**  
**Slide Inside Frame Post** (P/N 220-004) into Frame post. Install Index Plate lower bolt (finger-tight only).

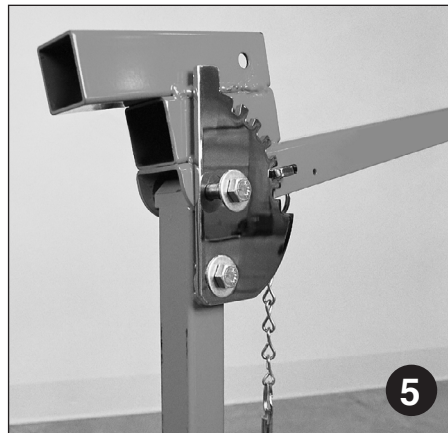

**5**  
**Install Trunnion Bracket** (P/N 220-005) using  $\frac{3}{8}$ " x 2" cap screw, through upper Index Plate hole.

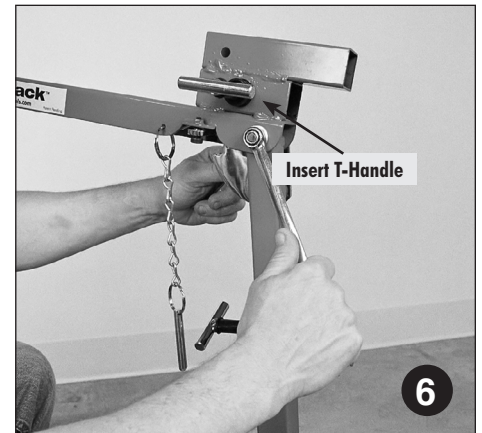

**6**  
**Attach Locking Hex Nut** to the 2" Cap Screw from step 5. **Do not overtighten.** Trunnion Bracket should rotate freely. Now firmly tighten lower Index Plate bolt.

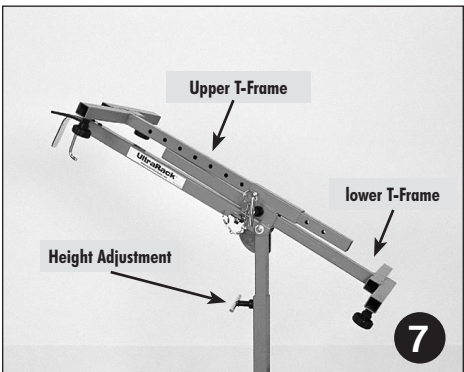

**7**  
**Insert T-Frame Tubes.**  
Upper T-Frame P/N 220-007.  
Lower T-Frame P/N 220-006.

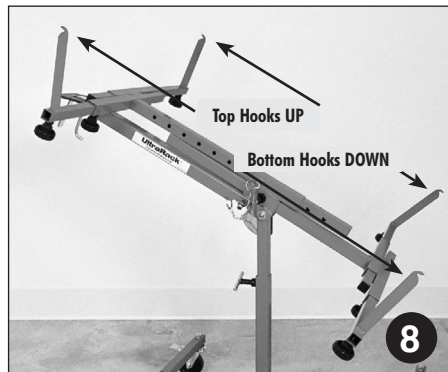

**8**  
**Insert Support Arms.**  
See arrows - hooks point away from center of UltraRack.

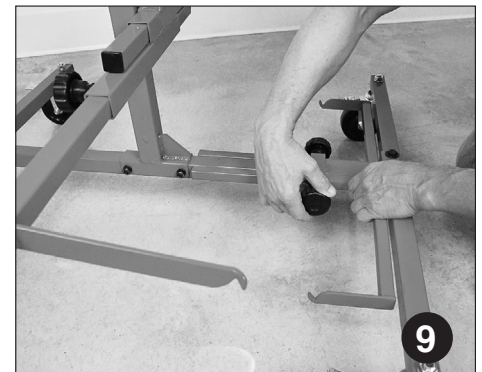

**9**  
**Put left and right Extension arms into storage position.** For use with pickup tailgates only.

# Innovative UltraRack™

Assembly Drawing

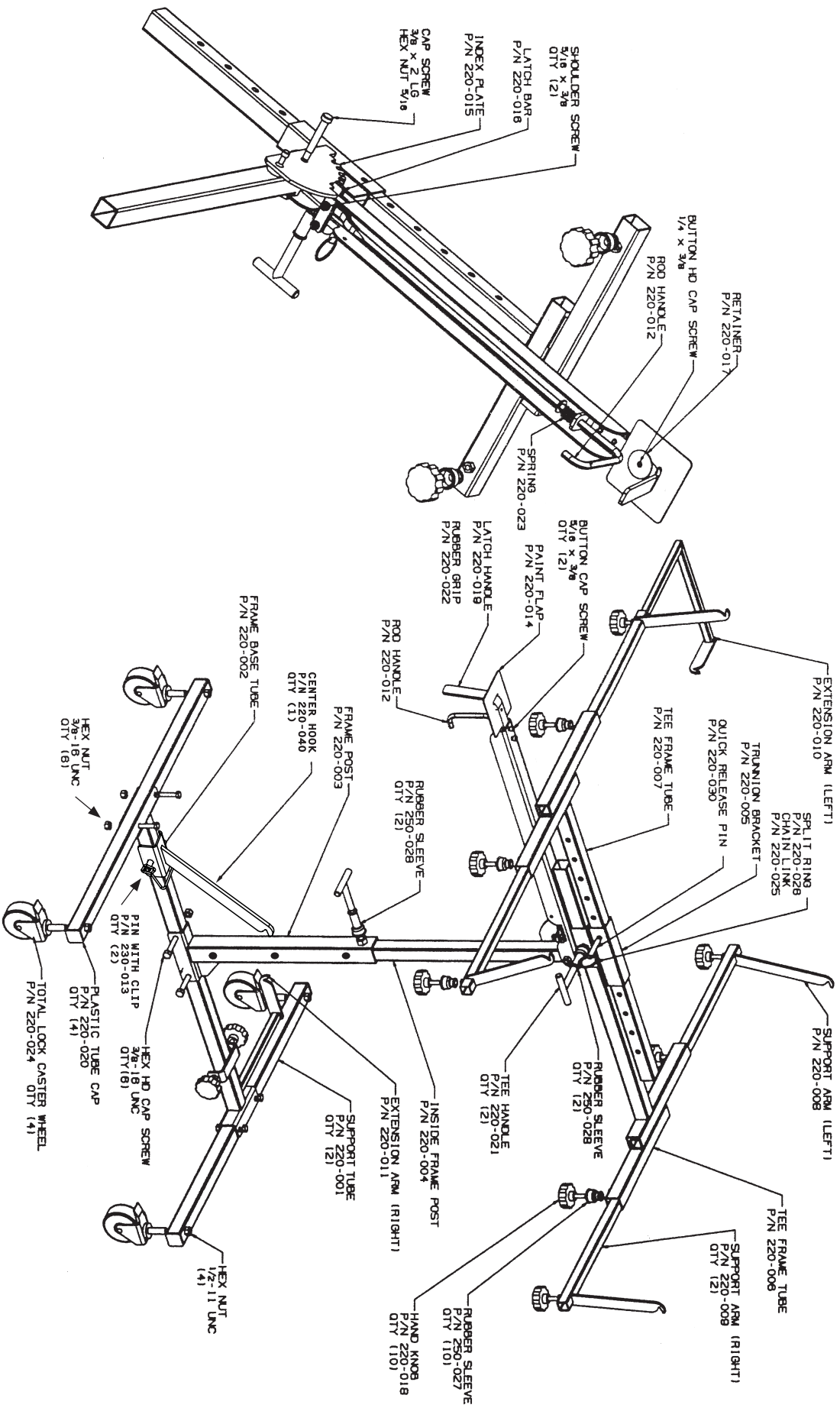

If you have any comments, questions or concerns about our products or are missing a part, please contact us toll-free at 1-866-438-4884 or 651-415-0733 or visit [www.innovativetools.com/contacts](http://www.innovativetools.com/contacts)